

Peeler/ Scrubber/ Washer – 2920/2922

Wash and Peel Products Efficiently for Your
Large-Scale, Around-the-Clock Operation



Vanmark's Peeler/Scrubber/Washers integrate product washing and peeling into one machine effectively and efficiently. The 2920 and 2922 models are available with six or eight rolls and are specifically designed for large scale, around-the-clock operations. Product is tumbled through a configurable combination of rollers, speed and settings – ensuring thorough cleaning and/or peeling. Spray bars and optional reversing roll quickly remove peel waste and debris to increase efficiency. Its exclusive Natural Flow Gate minimizes dead spots and over-peeling – increasing yield.

- Clean and peel product efficiently and effectively in one machine
- Flow rates up to 10,000 pounds per hour of storage potato capacity
- Configure roll types, number of rolls, speed and discharge gates to your exact operation
- Further specialize with options including a tumbling unit that continuously moves odd-shaped products
- Exclusive Natural Flow Gate dramatically reduces peel loss and increases yield compared to conventional dams or auger gates
- Sanitary design with quick roll change system and easy access peel chamber allows for quick and thorough cleaning

Common Food Applications

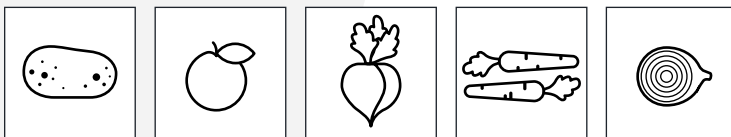

Potatoes

Apples

Beets

Carrots

Onions

Peeler/Scrubber/Washer – 2920/2922

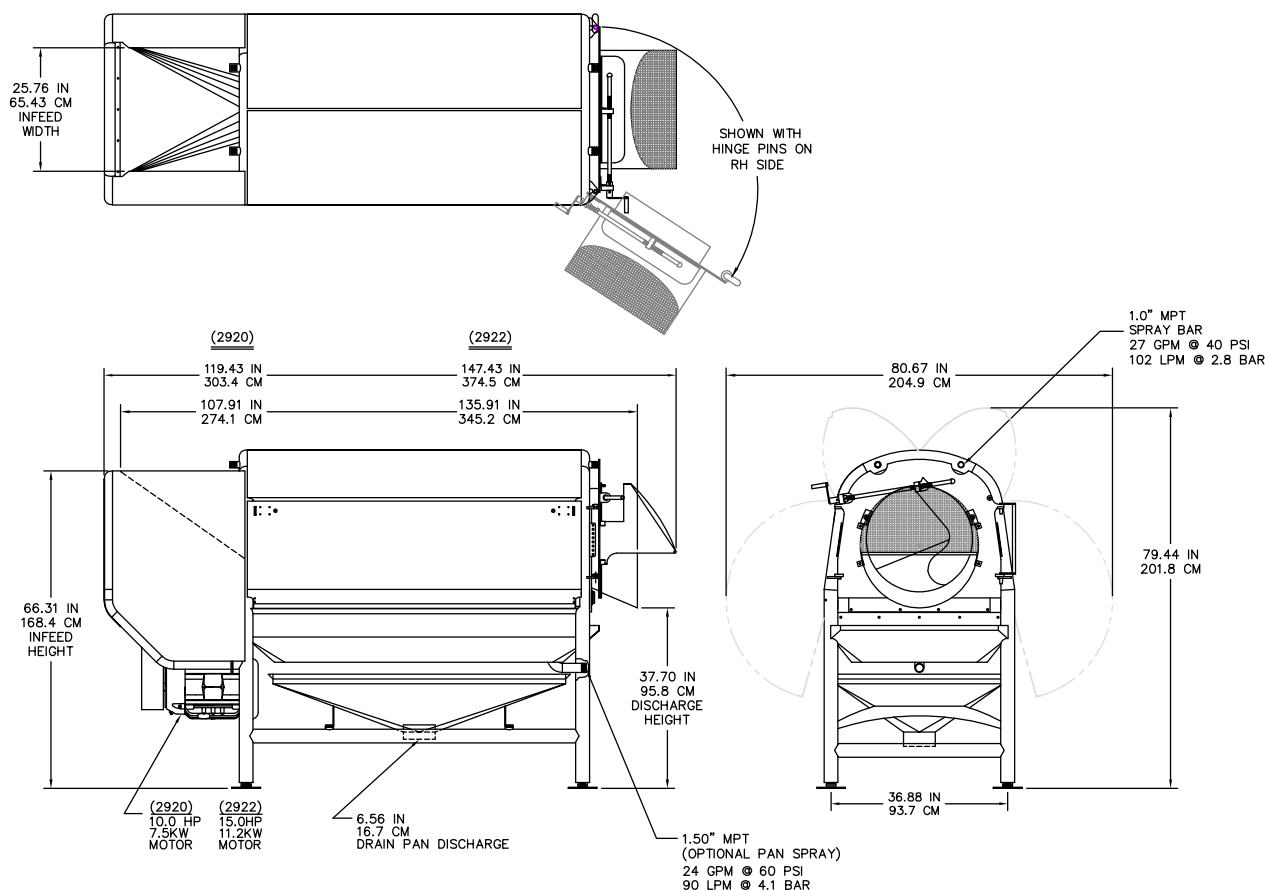

Specifications

Roll Speed: 100-550 RPM

Water: 40 psi, 27 GPM maximum

Motor:

Model 2920: 10 HP

Model 2922: 15 HP

Weight:

Model 2920: 2500 lbs. (1134 kg)

Model 2922: 2900 lbs. (1450 kg)

Features

- Available with six or eight rolls
- Available roll types: rubber finger (knocker), rubber pintle, brushes and coated abrasive
- Variable speed control requires a customer-supplied inverter or Vanmark-provided inverter at an additional cost
- Includes trapped key door interlock system (24V or 120V)

Options

- Options: reversing roll, auger discharge, automatic lubrication system, under-roll or peel chamber CIP cleaning system, tumbling unit

Contact Us

Vanmark is proud to provide top quality equipment, exceptional service and peace of mind worldwide for the potato and produce processing industries. Contact us for more information and to custom-fit the Peeler/Scrubber/Washer – 2920/2922 for your specific application.



To feed our growing world - Together

Phone: +1 740-201-0004

Email: sales@vanmark.com

vanmark.com